

The Commercial  
LED Lighting Specialist

**Superlight<sup>®</sup>**

**LED FLOOD LIGHTS**

**PRODUCT CATEGORY DATA SHEET**

# PRODUCT DATA SHEET

## LED Module Flood Light | 25W



### FEATURES:

Brand	Superlight
Wattage	25W
Voltage	220-240V AC
Lifetime	20.000 hours
Power Factor	>0.5
Luminous Flux	2.500Lm
Colour	6500K
Dimensions	157x94x67mm
Warranty	One year

Model Number

**25w Flood Light**

### Dimension:

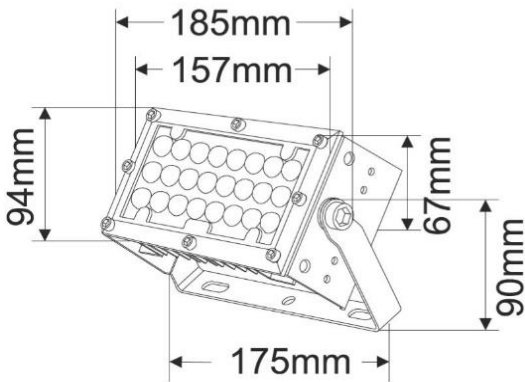

**Front View**

### Advantages:

- IP67, isolated driver, much safer.
- Light weight and easy to combine.
- Small size, save space, more quantities for one container.
- Plastic lens, breakage-proof.
- High lumen output.
- Less light pollution, energy saving.

### Light Distribution Curve:

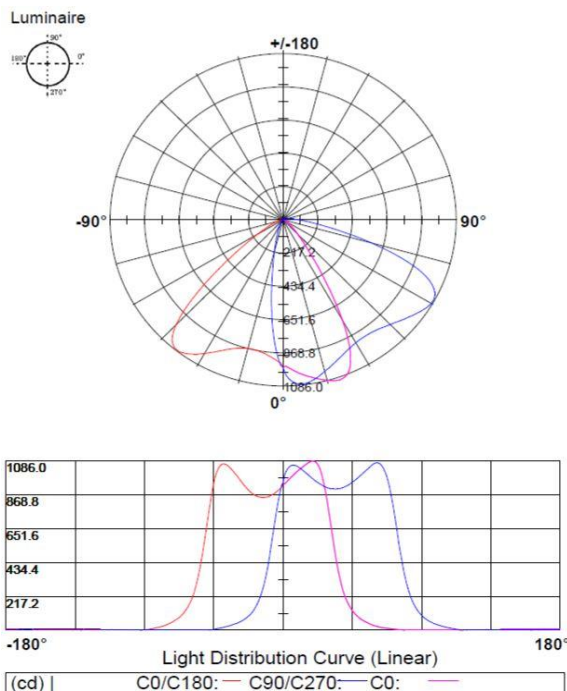

### Lux-Distance Curve:

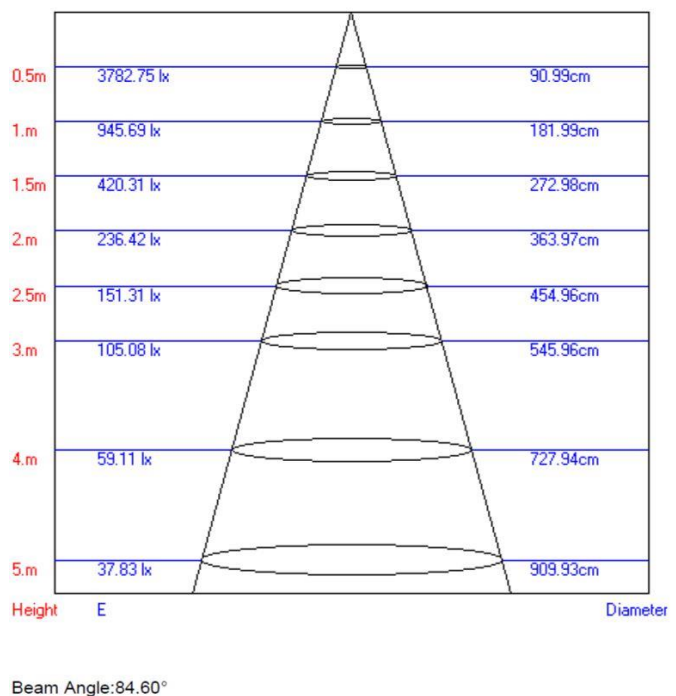

# PRODUCT DATA SHEET

## LED Module Flood Light | 50W



### FEATURES:

Brand	Superlight
Wattage	50W
Voltage	220-240V AC
Lifetime	20.000 hours
Power Factor	>0.5
Luminous Flux	5.000Lm
Colour	6500K
Dimensions	157x188x67mm
Warranty	One year

Model Number

**50w Flood Light**

### Advantages:

- IP67, isolated driver, much safer.
- Plastic lens, breakage-proof.
- High lumen output.
- Less light pollution, energy saving.

### Light Distribution Curve:

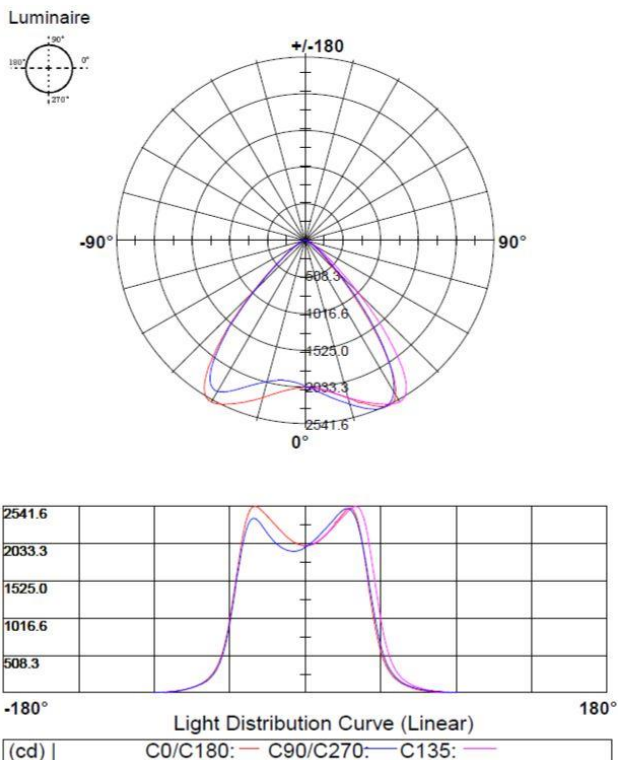

### Lux-Distance Curve:

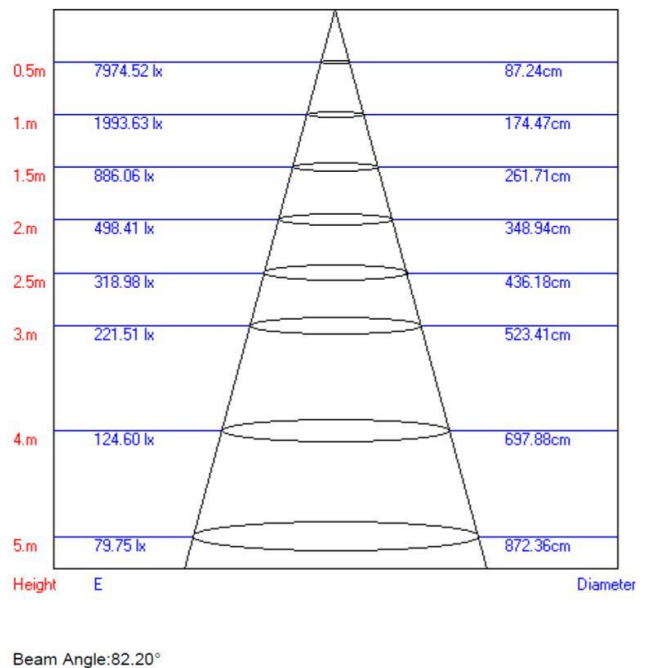

# PRODUCT DATA SHEET

## LED Module Flood Light | 50W



### FEATURES:

Brand	Superlight
Wattage	50W
Voltage	220-240V AC
Lifetime	20.000 hours
Power Factor	>0.5
Luminous Flux	5.000Lm
Colour	6500K
Dimensions	157x188x67mm
Warranty	One year

Model Number

**50w Flood Light**

### Advantages:

- IP67, isolated driver, much safer.
- Plastic lens, breakage-proof.
- High lumen output.
- Less light pollution, energy saving.

### Light Distribution Curve:

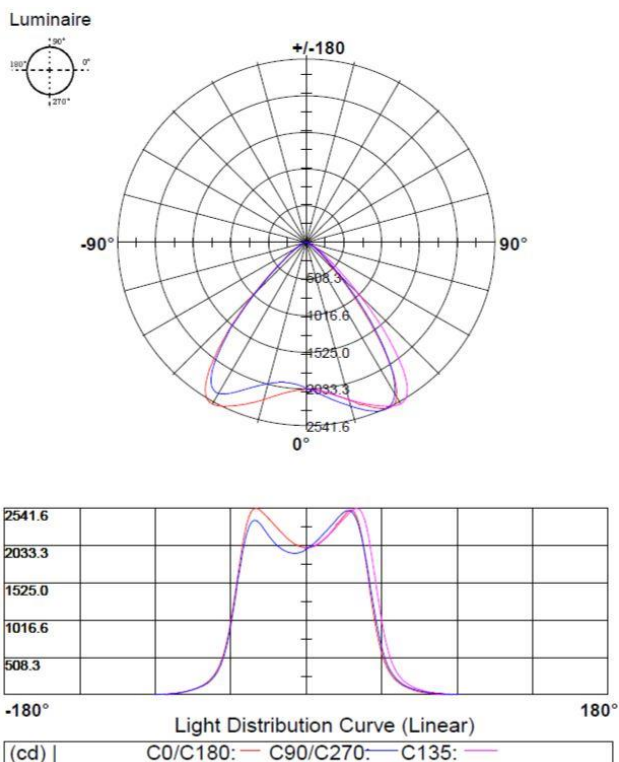

### Lux-Distance Curve:

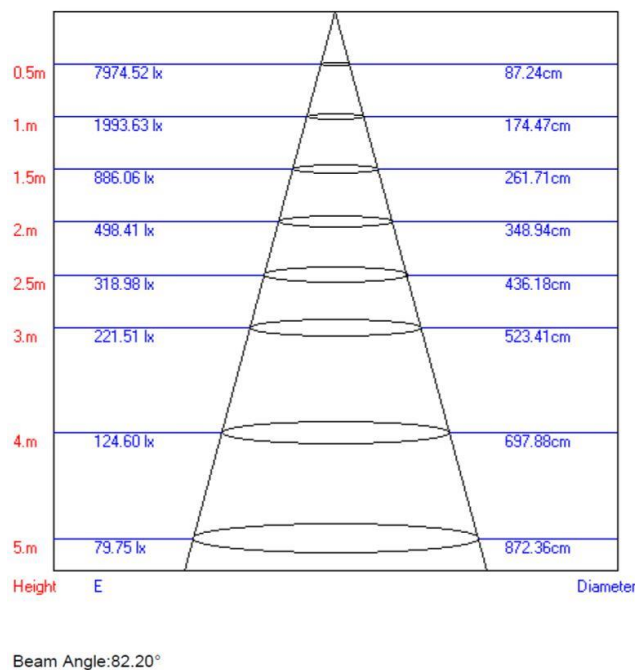

# PRODUCT DATA SHEET

## LED Module Flood Light | 100W



### FEATURES:

Brand	Superlight
Wattage	100W
Voltage	220-240V AC
Lifetime	20.000 hours
Power Factor	>0.5
Luminous Flux	10.000Lm
Colour	6500K
Dimensions	314x188x67mm
Warranty	One year

Model Number

**100w Flood Light**

### Advantages:

- IP67, isolated driver, much safer.
- Plastic lens, breakage-proof.
- High lumen output.
- Less light pollution, energy saving.

### Light Distribution Curve:

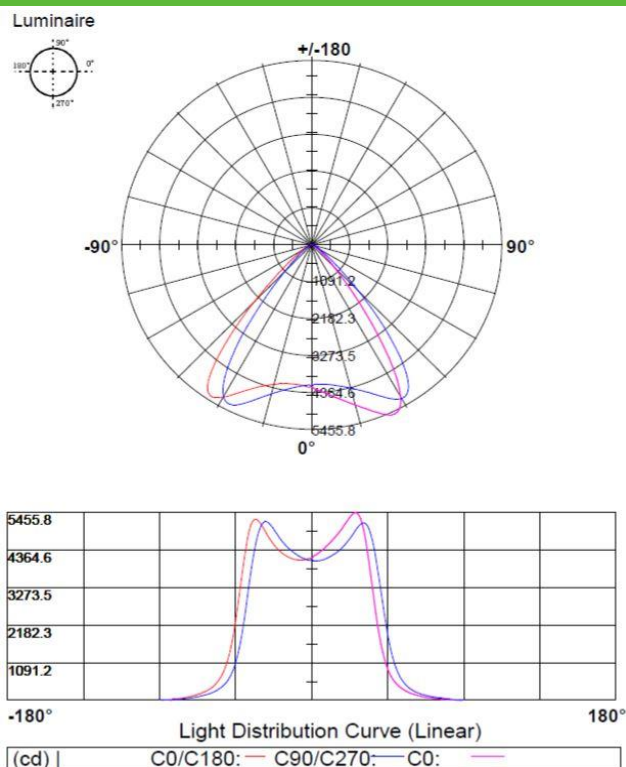

### Lux-Distance Curve:

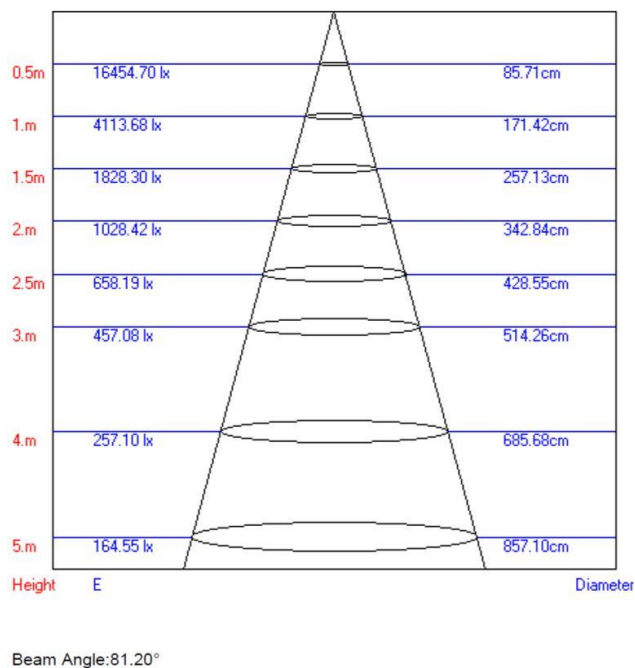

# PRODUCT DATA SHEET

## LED Module Flood Light | 150W



### FEATURES:

Brand	Superlight
Wattage	150W
Voltage	220-240V AC
Lifetime	20.000 hours
Power Factor	>0.5
Luminous Flux	15.000Lm
Colour	6500K
Dimensions	314x282x67mm
Warranty	One year

Model Number

**150w Flood Light**

### Advantages:

- IP67, isolated driver, much safer.
- Plastic lens, breakage-proof.
- High lumen output.
- Less light pollution, energy saving.

### Light Distribution Curve:

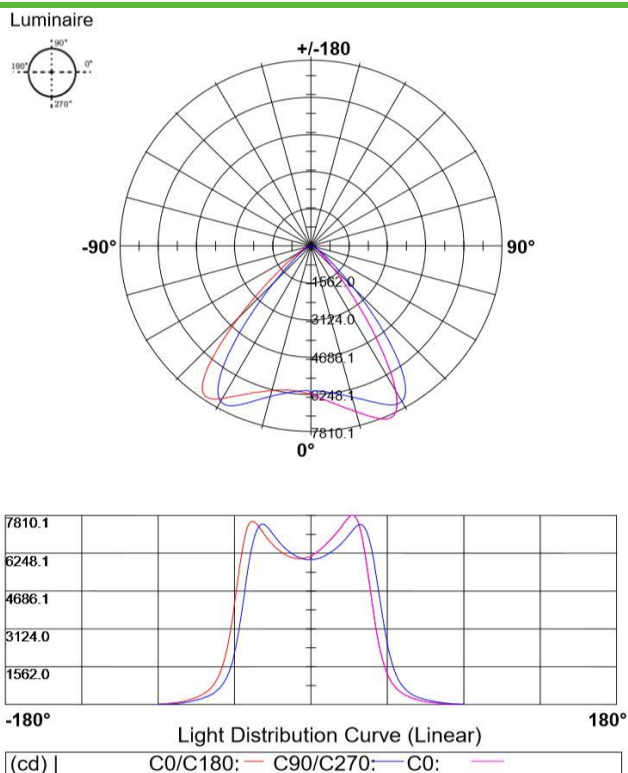

### Lux-Distance Curve:

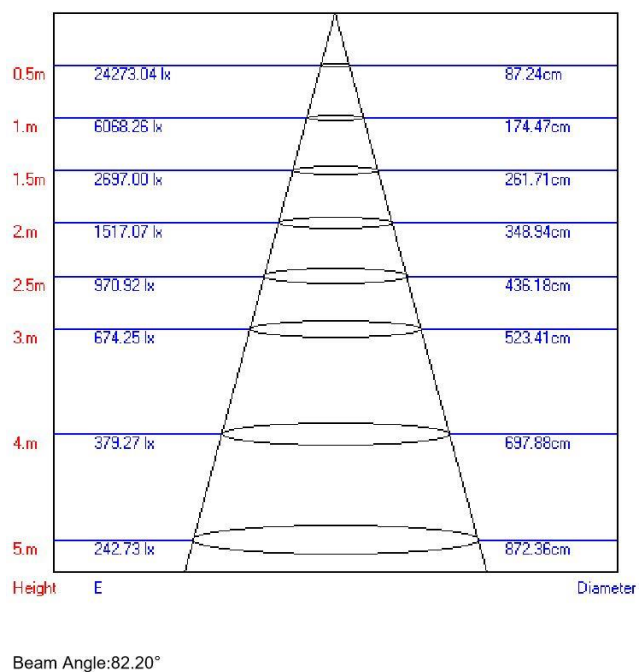

# LED FLOOD LIGHT

## Summary

Model Number	Decription	Power	Colour Temperature	Lumens
25w Flood Light	157x94x67mm	25W	6500K	2500Lm
50w Flood Light	157x188x67mm	50W	6500K	5000Lm
75w Flood Light	157x282x67mm	75W	6500K	7500Lm
100w Flood Light	314x188x67mm	100W	6500K	10000Lm
150w Flood Light	314x282x67mm	150W	6500K	15000Lm